

SE (Sem IV) EXTC (CG)

Control System

Q.P. Code : 546202

(3 Hours)

[Total Marks : 100

- N.B. : (1) Question No. 1 is compulsory.
 (2) Answer any four out of remaining six questions.
 (3) Figures to the right indicate full marks.
 (4) Assume suitable data if necessary.

1. Answer the following :-

20

- (a) Explain the concept of relative stability.
- (b) What do you mean by frequency domain analysis and explain the frequency domain performance indices.
- (c) Find out the T.F. of the given network.

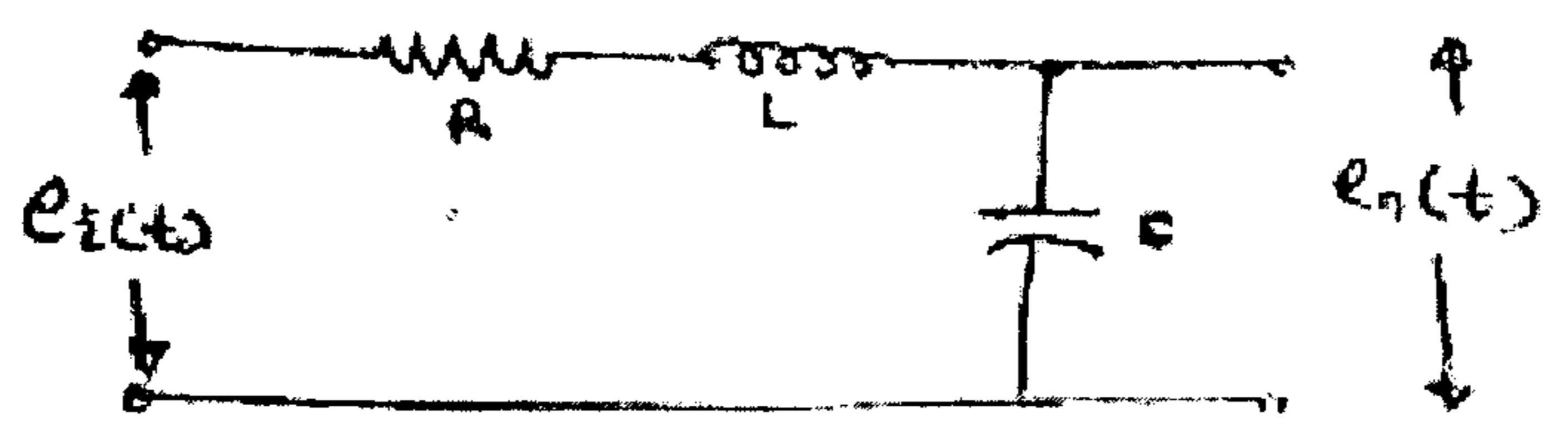

- (e) The forward path gain of a system is 2.5 and Pole-zero configuration of the system is shown below, find the overall transfer function and type of the system for unity feedback.

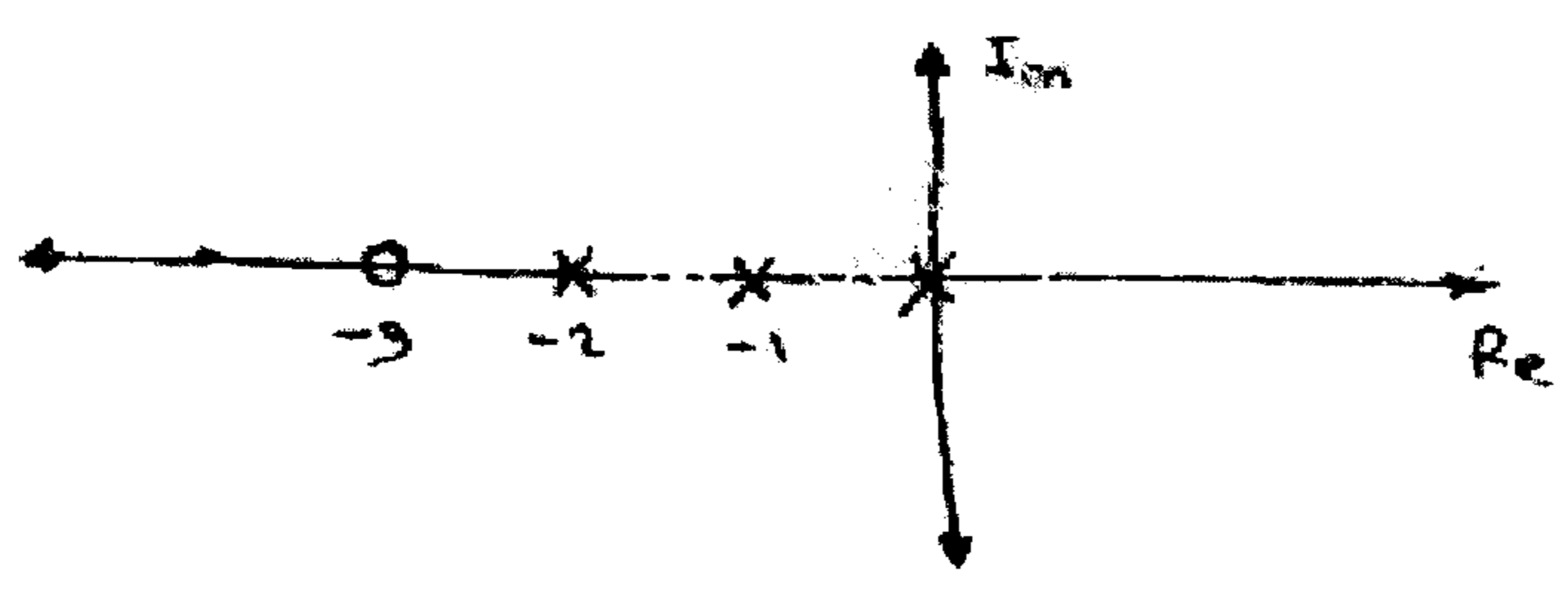

2. (a) Reduce the block diagram and obtain its transfer function.

10

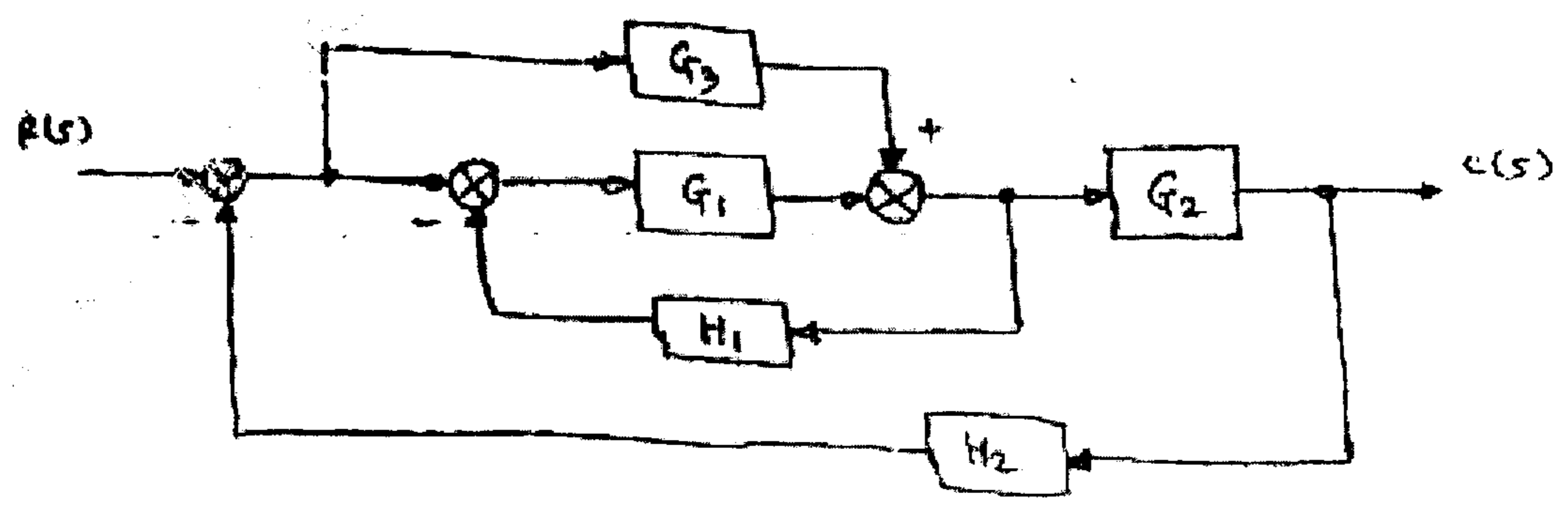

TURN OVER

- (b) Draw the corresponding signal flow graph of given block diagram and find $\frac{C(s)}{R(s)}$ 10

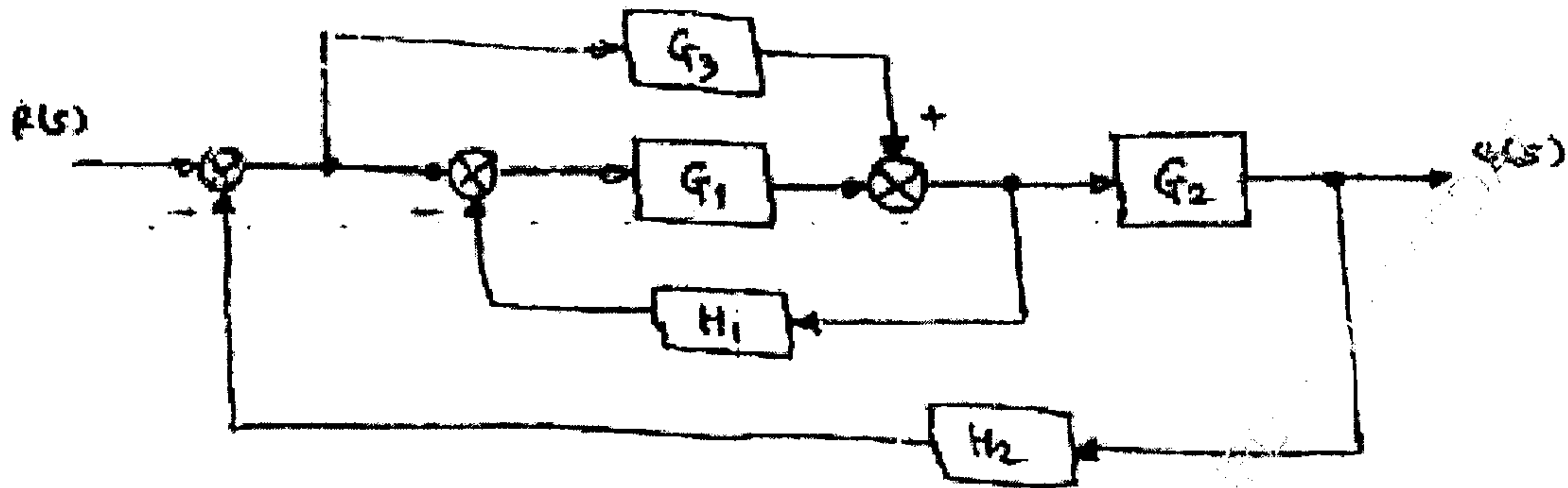

3. (a) State and prove properties of state transition matrix and check controllability and observability for the system. 10

$$\dot{x} = \begin{bmatrix} 0 & 6 & 5 \\ 1 & 0 & 2 \\ 3 & 2 & 4 \end{bmatrix} x - \begin{bmatrix} 0 \\ 1 \\ 2 \end{bmatrix} u$$

$$y = [1 \quad 3 \quad 0]x$$

- (b) A unity feedback system has - 10

$$G(s) = \frac{40(s+2)}{s(s+1)(s+4)}$$

- Determine : (i) Type of the system
(ii) All error coefficients
(iii) Error for ramp input with magnitude 4.

4. (a) Discuss the stability of the following systems for given characteristic equation using Routh-Hurwitz criterion. 10

(i) $s^6 + 4s^5 + 3s^4 + 16s^2 - 64s - 48 = 0$

(ii) $s^6 + 2s^5 + 8s^4 + 12s^3 + 20s^2 + 16s + 16 = 0$

- (b) A feedback control system has an open-loop transfer function. 10

$$G(S) = \frac{K}{S(S+3)(S^2+2S+2)}$$

Find the root-locus as $k \rightarrow 0$ to ∞

SE (sem) IV EYTC

Q.P. Code : 546202

3

5. (a) For a particular unity feedback system, **10**

$$G(S) = \frac{242(s - 5)}{s(s - 1)(s^2 - 5s - 121)}$$

Sketch the Bode plot and find W_{gc} , W_{pc} , G.M., P.M. and comment on stability.

- (b) For a certain control system **10**

$$G(s).H(s) = \frac{K}{s(s + 2)(s + 10)}$$

Sketch the Nyquist plot and hence calculate the range of K for stability.

6. (a) Explain the frequency domain specifications. **20**
(b) Explain the concept of Neuro-Fuzzy adaptive control system.
(c) Write short note on : Steady state errors in feed back control system and their types.
-